

HAFELE APPLIANCES

HAFELE

Maximising  
the value of space.  
Together.



ESSENTIA SERIES

# Maximising the value of space. Together.

Hafele's history is a story of consistent movement from furniture to the door into the room. Our path has led from functionality to atmosphere and connectivity and on to a sustainable view of the customer process – from product development to after sales support. In addition to our dynamic entrepreneurial spirit, this passion for meeting customer needs has been an essential part of our DNA since the foundation of the company by Adolf Hafele. And that is what we want to continue to strengthen in the future.

Hafele's brand purpose, 'Maximising the value of space. Together,' serves as a guiding compass, leading us in crafting holistic and sustainable environments for our customers where they can enjoy the multiplied benefits of their living and working spaces.

Our purpose has 4 dimensions – **Functional, Intelligent, Atmospheric and Organised.**

# HÄFELE

### **Atmospheric:**

When we move around in rooms, we experience the functions and the technology, and emotions are invoked as well. These have to do with well-being and orientation, qualities that we often perceive on an unconscious level. That's why we have been working with the topic of light to create a unique selling point in the market with the systematic combination of furniture and room lighting – which also improves the quality of the atmosphere in the room, no matter whether the space is designed for living or working.

### **Functional:**

This has been the core of our business for a hundred years now. But it's about more than just opening or closing furniture. It's about more convenience for the user, it's about flexibility and multi-functionality, it's about reliability, quality and longevity, it's about making ideas possible and it's about inspiration for our customers.

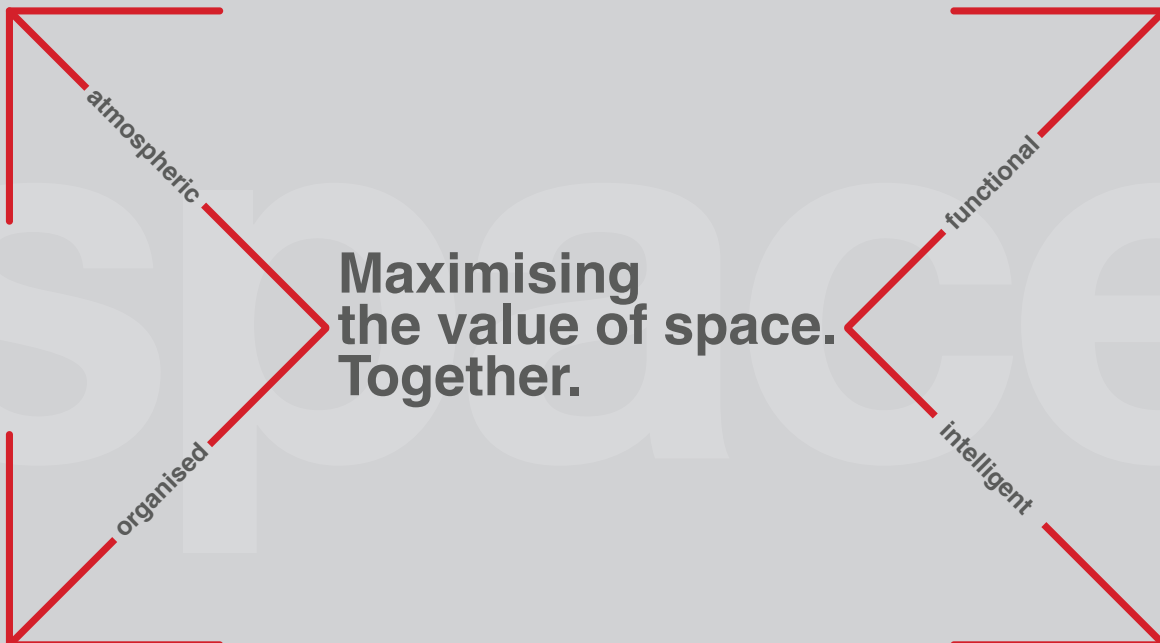

### **Organised:**

We not only take care of products and solutions, but also our customers' processes. No matter whether they have to do with the manufacture of furniture or with the development for project business. We want to provide our customers with tangible added value by helping them achieve goals easier, faster, safer, and more efficiently. For instance, we can do this with customised planning services or specialized installation services for our customers.

### **Intelligent:**

Homes are becoming intelligent and so are our range of products and services. Thanks to our smart appliances and digital security solutions, the components in the room can be controlled easily and conveniently and can also be connected with other smart systems as needed. We strive to be an innovative player in the digital world of today and tomorrow.



We asked ourselves two questions.

**WHO** are we? And **WHY** are we the way we are?

And we found **ONE ANSWER!**

We are attentive & determined!

Attentive to the needs of our customers and...

Determined to constantly better things that matter to them.

**Innovative. Intuitive. Intelligent.**

We listen to the smallest needs our customers may have and challenge ourselves to fulfil them.

**Form. Function. Focus.**

We are wired to think practically, design aesthetically, perform efficiently and pay attention to details.

**Curious. Creative. Conscious.**

We are a 100-year-old organization, driven by a young mindset and out-of-the-box ideas. We respect our environment, our people, our stakeholders and above all our customers; and so, we believe in a single charter - make it better.

**Simple. Smart. Solution.**

We are the friend that cares about the things that matter to our customers – big or small.

We are the catalyst that transforms their spaces into functional, organised, atmospheric and intelligent homes.

We are the partner that brings it all together!

We are **Hafele!**

# HAFELE

Maximising  
the value of space.  
Together.

# Hafele Worldwide



With its origin in 1923 in a small town named 'Nagold' from the Swabian region of Germany that nurses a passion for hardware technology, it is no surprise that Hafele has lived up to its roots through a successful presence in the architectural and furniture hardware industry for over 10 decades now. Today, Hafele's worldwide penetration includes 38 subsidiaries across Europe, America, Asia, Australia and New Zealand. With these subsidiaries and numerous other sales organisations, Hafele operates in over 150 countries. The Hafele headquarters, 4 manufacturing units and 10 sales offices are located within Germany; while 1 manufacturing unit is located at Budapest, Hungary. The company also owns one of the largest and most sophisticated warehouses in its home country. The Hafele worldwide workforce is empowered by a base of over 8100 employees.

The group services over 150,000 customers across the globe through its extensive range of hardware products and a comprehensive logistics system. In addition to this, Hafele also provides consultative services to its customers, educating and advising them about buying the correct hardware as per their requirements. With this level of market penetration and ability to handle worldwide demand, it comes as no surprise that the company is an authority in the segment of home interior solutions; what is pleasantly surprising, though, is that in spite of its size, Hafele still remains a family owned and run business with a unique, friendly and value-centric work culture which is strongly followed among all its subsidiaries.

# Hafele India

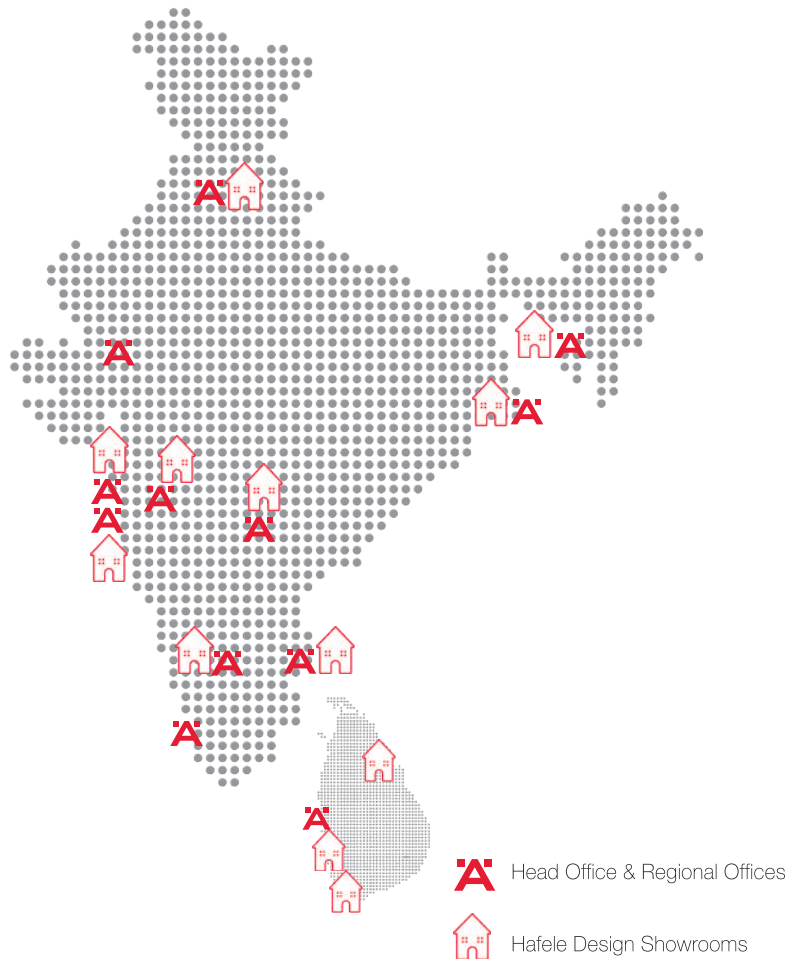

Hafele India is a wholly-owned subsidiary of the Hafele Global network and has been operating in India since 2003. The ability of the company to understand the diverse Indian market has made it an authority in the field of architectural hardware, furniture and kitchen fittings and accessories. The company also has a strong presence in synergized product categories namely Home Appliances, Interior Lighting, Water Solutions and Surfaces catering to the focused demand from these industries.

The subsidiary has a strong nation-wide presence with offices in Mumbai, Pune, Ahmedabad, Bangalore, Chennai, Hyderabad, Cochin, Delhi and Kolkata. It has full-scale operations in Sri Lanka and Bangladesh with Regional offices and Design Showrooms in both the countries; and has also spread its operations to other regions of South Asia including Nepal, Bhutan and Maldives.

Hafele's design showrooms are hubs of international home interior trends and cutting-edge designs presented in a world-class environment, where customers can see home solutions in their inherent applications. These showrooms function as a one-stop-shop for all home interior and improvement needs - from providing in-depth technical advice to kitchen and wardrobe designing services through a team of experts stationed at the showroom.

Hafele India services its customers with a base of 1500 employees, a well-networked Franchise base of over 180 Partners along with over 500+ direct dealers and 90+ distributors who in turn cater to over 12000+ sub dealers. The subsidiary has a sophisticated Logistics centre in Mumbai along with distribution centres in Delhi, Bangalore, Kolkata and Colombo respectively.



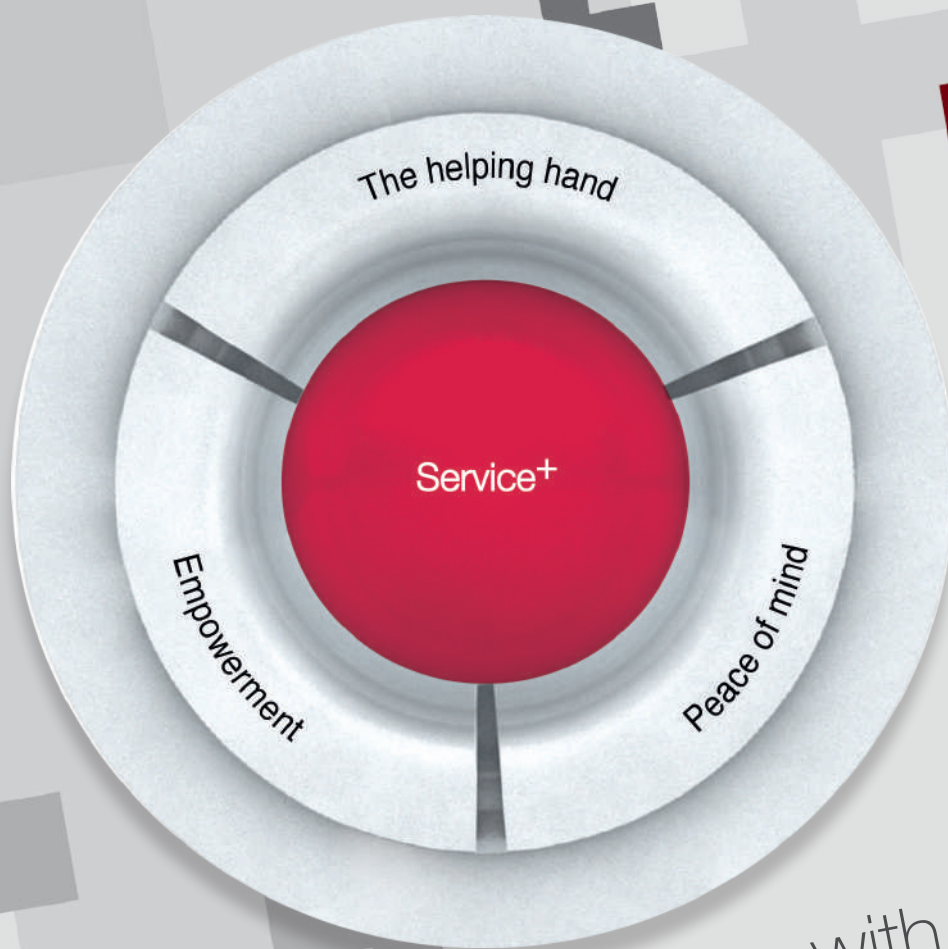

## Experience More with **Service+**

Our customers' working environment is becoming increasingly complex and their market is becoming ever more demanding. This drives our motivation to do everything in our power to help our customers be successful. And to demonstrate that Hafele is the right partner in these challenging times, we want to accompany our customers throughout their entire business process and give them added strength in every phase of their business. We don't just want to sell our products, we also want to provide the highest level of service.

We have now divided our services into two categories: **Standard Services** which we provide to our customers as a matter of course when they choose our products. For example, a high availability of our goods and punctual delivery. And then there is **Service+** which constitutes of services that give our customers considerable added value in terms of building expertise, increasing productivity or providing individual customised solutions. These services require a considerable amount of time and effort to develop and implement and are designed to enable our customers to regard them as worthwhile investments.

The aim is to create solid long-term foundations for our comprehensive service promise and to make Hafele an indispensable partner for our customers. The focus here lies not so much on us and on what we do – but rather, on the benefits derived by our customers. We want to **empower** them with opportunities to develop and expand their skills – both as masters of their trade and as entrepreneurs. We want to support them in the planning and realisation of their projects and relieve them of as much work as possible, thereby providing them with a **helping hand** to use their most valuable resource – time – as efficiently as possible. And we aim to give our customers **peace of mind** and the assurance that even after the end of a successful project completion, we will continue to be there for them as a reliable partner, shouldering responsibility.



# The Pillars of **Service+**

In order to support you as comprehensively as possible, we have assigned the Plus Services to individual stages of your work process in a total of four themed pillars. We start with the transfer of knowledge and accompany you via planning and production to installation and maintenance.



Empowering customers with  
**Service+ Knowledge**

Includes service offerings that provide inspiration and expertise to our customers about the Hafele product range. Through these, we enable our customers to use Hafele products profitably and at the same time remain at the cutting edge of technological development. One example of this is the Hafele Academy, which imparts knowledge about complex products and new technologies to our customers via seminars and trainings.

Providing a helping hand to customers with  
**Service+ Planning & Customised**

Includes service offerings like space, design planning and customisations that make life easier for our customers and support their design vision. An example of this is Hafele's Lighting Design Service which helps our customers curate a lighting plan, following a customised approach, that enhances and brings out the true functionality of the interior space as per requirement.



Lending a "Peace-of-mind" experience through  
**Service+ Assist**

Includes service offerings that provide support and assistance to our customers, whether digitally or on site. An example of this is the complete assembly and installation service for more complex and maintenance-intensive products done by our Meister certified and trained technicians.



**Service+**  
Knowledge

**Service+**  
Assist



# Service Partner Network

From the very start Hafele has kept a strong focus on strengthening our overall service offering for the Appliances business. Over the years, we have appointed Service Franchisees across the country, in addition to our trained and certified team of in-house service engineers. Today, our service network includes a certified team of in-house engineers along with over **126 service partners** across the country housing **370+ service technicians** who work tirelessly to meet every service request. Under the Service+ Assist initiative, this team takes care of all post-purchase service requests from installation of appliances to conducting demonstrations as well as resolving complaints, if any. In addition to this, our Hafele Care App makes life easy for customers who can book services, raise inquiries or even get product information on the go.

As we continue to strengthen our service network to ensure easy and quick access to our different services, our on-going focus also remains to provide skilled and top of the line service to all customers through robust training of all our service franchisee engineers. A step was taken in this direction by deploying training centres across the country for a nation-wide penetration. The Appliances Training Centres provide state of the art technical trainings to all service franchisee personnel associated with Hafele, thereby strengthening our core objective under Service+ Knowledge of empowering our service network. Equipped with all types of Products to encourage practical training sessions, these centres will focus on enhancing the knowledge of service engineers through a realistic and tangible experience.

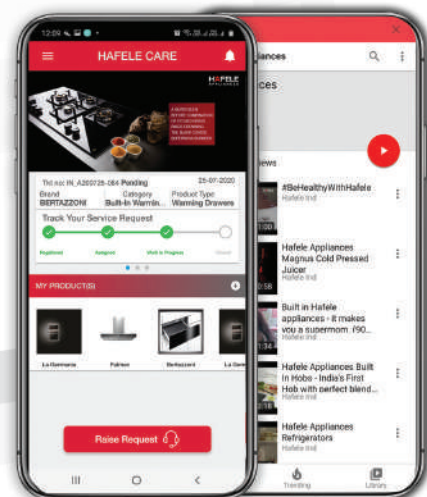



# ESSENTIA SERIES

## Seamless Blend of Functionality and Design

Since 2014, Hafele Appliances has been a game-changer in the Indian kitchen space, offering innovative technologies and comprehensive solutions in the Built-in segment. Hafele has introduced numerous groundbreaking technologies in India, including the iconic Teresa cookerhood featuring Filter-free technology, revolutionizing the cookerhood market and establishing Teresa as a renowned brand synonymous with Inclined, filter-free cookerhoods. Another pioneering innovation from Hafele is Altius FS, India's first fully sealed hob, showcasing the brand's commitment to innovation and quality. Additionally, Hafele has innovatively designed built-in ovens and microwaves as family sets, enhancing the aesthetic appeal and functionality of modern kitchens.

Hafele now introduces the ESSENTIA SERIES, a fusion of elegance and efficient design, tailored for someone who wants to embark on a journey of modernising their kitchen with built-in appliances. Built with German precision and adapted for Indian culinary diversity, these appliances seamlessly blend functionality with exquisite design. The AUGUSTA AND VERENA HOBS, adorned with brass burners and the Flame Failure Safety Device deliver both quality and safety, while ensuring optimal cooking performance. Accompanying them, the RENATA and CURVE BOLT 60 COOKERHOODS simplify kitchen maintenance with their filter-free technology offering a smoke-free kitchen.

With the ESSENTIA SERIES, Hafele invites you to embrace the perfect fusion of style and functionality, making every culinary endeavour a delightful experience.



# RENATA HOODS

## Effortless Elegance, Unmatched Performance

Discover unmatched convenience and elegance in your kitchen with RENATA COOKERHOODS from the ESSENTIA SERIES by HAFELE. Renata, which means 'reborn' in Latin, truly encapsulates the essence of the Essentia Series, inviting you to rediscover the art of cooking. Available in three exquisite designs - CURVED, INCLINED, and T-SHAPED, these cookerhoods are a perfect blend of aesthetics and functionality. Their filter-free design ensures easy maintenance, freeing you from the hassle of frequent filter replacements. Equipped with a powerful motor, these cookerhoods efficiently extract smoke and odors, always keeping your kitchen fresh and clean.

Featuring intelligent heat auto-clean technology, these cookerhoods offer automatic cleaning, saving you time and effort. The touch control panel with gesture control adds a new dimension of convenience to your cooking experience, allowing for effortless operation with just a swipe of your hand. The sophisticated black finish of the RENATA COOKERHOODS enhances your kitchen's aesthetics.



# RENATA HOODS

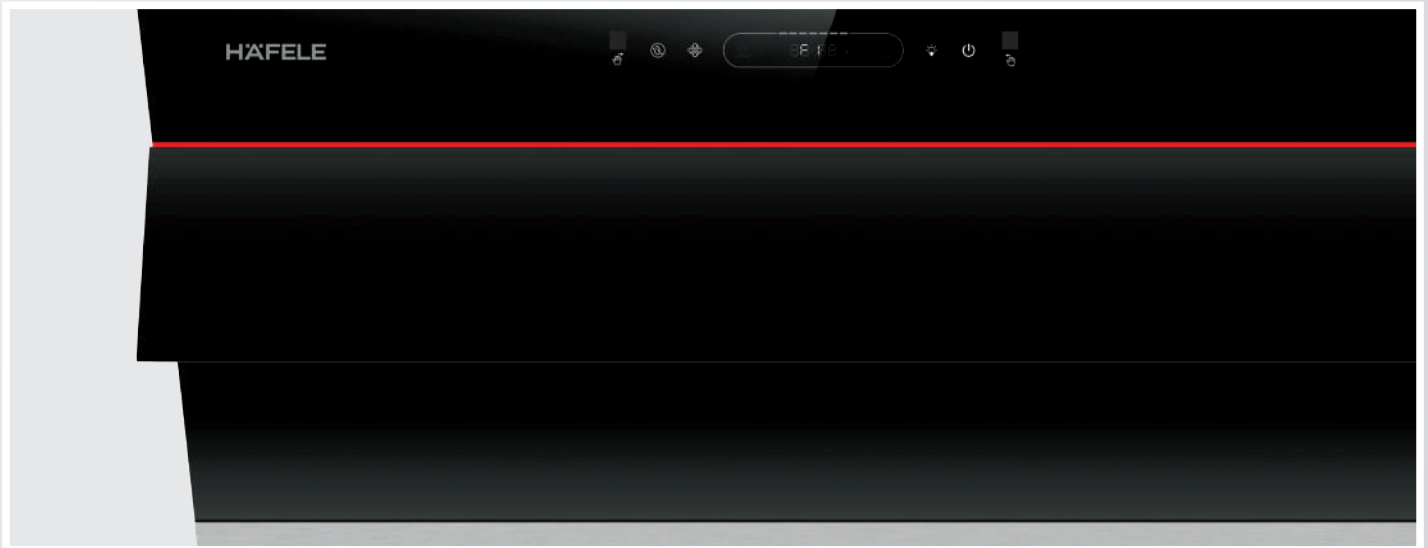

## Filter-Free Technology with Auto-Open Panel

The filter-free design of Renata Cookerhoods eliminates the need for regularly cleaning/changing filters, enhancing both convenience and peace of mind. The Auto Open Panel, integrated into Renata Inclined cookerhoods, which opens by itself when the cookerhood is switched on, not only presents itself as an ergonomic feature but is also effective in capturing maximum volume of smoke before its dispersion.



## Heat Auto-Clean Technology

Renata Cookerhoods feature the Intelligent Heat Auto Clean technology, offering a hassle-free method for effectively cleaning your hood. With an integrated heating element, the hood heats the inner walls, effortlessly melting away accumulated oil and grease particles. These residues are then collected in the removable oil collector, facilitating easy cleaning. This intelligent cleaning function automatically puts the cookerhood into the cleaning mode after 30 hours of operation.

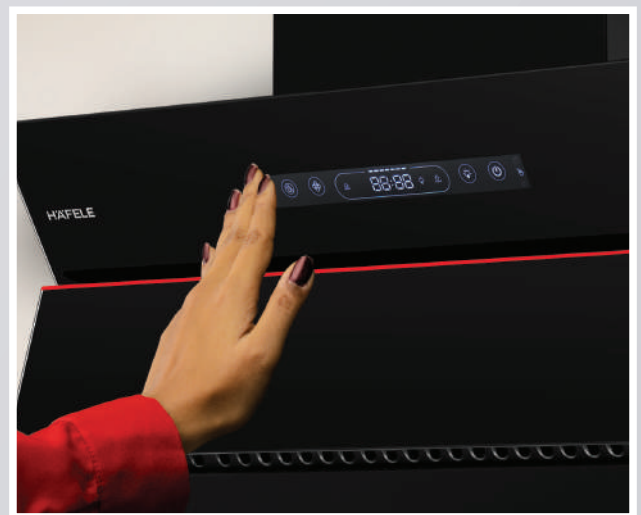

## Gesture Control

Equipped with intelligent motion sensors that allow for hand gesture control, these cookerhoods ensure hands-free operation, preventing the need to touch the control panel with greasy hands, thereby keeping it clean by enabling functions such as turning on, turning off, or adjusting the motor speed of the cookerhood without any difficulty.



## Efficient Extraction of Smoke and Fumes

The powerful motor integrated into these cookerhoods enables efficient and quick extraction of cooking fumes and smoke, enabling you to continue cooking your favourite delicacies without interruptions.



## Feather Touch Control Panel

These cookerhoods are equipped with a capacitive touch control panel featuring a digital LCD display, providing precise and swift control over its functions with just a touch, thereby enhancing convenience.

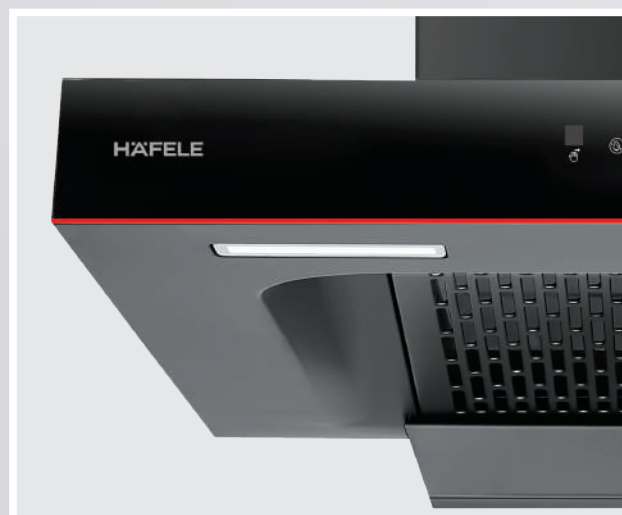

## LED Lighting

The highly luminous LED lights illuminate the hob countertop, offering a clear view of your cooking progress.



### RENATA INCLINED 90

90 cm Wall Mounted **Filter-Free** Hood

Finish	Black Glass
Motor Power	200W
Speed Level	3 Speed Touch with Gesture Control
Timer Function	Yes
Auto Clean	Heat Autoclean with 30 Hour Timer
Filters	Filter-free
Lighting	LED
Inlet Side Suction*	1300m <sup>3</sup> /h
Product Dimensions (W X H X D) mm	897 X 848 X 340
Warranty	2 years on Hood, 10 years on Motor

**Article No. 534.84.513**

### RENATA INCLINED 75

75 cm Wall Mounted **Filter-Free** Hood

Finish	Black Glass
Motor Power	200W
Speed Level	3 Speed Touch with Gesture Control
Timer Function	Yes
Auto Clean	Heat Autoclean with 30 Hour Timer
Filters	Filter-free
Lighting	LED
Inlet Side Suction*	1300m <sup>3</sup> /h
Product Dimensions (W X H X D) mm	747 X 848 X 340
Warranty	2 years on Hood, 10 years on Motor

**Article No. 534.84.512**

### RENATA INCLINED 60

60 cm Wall Mounted **Filter-Free** Hood

Finish	Black Glass
Motor Power	200W
Speed Level	3 Speed Touch with Gesture Control
Timer Function	Yes
Auto Clean	Heat Autoclean with 30 Hour Timer
Filters	Filter-free
Lighting	LED
Inlet Side Suction*	1300m <sup>3</sup> /h
Product Dimensions (W X H X D) mm	597 X 848 X 340
Warranty	2 years on Hood, 10 years on Motor

**Article No. 534.84.511**

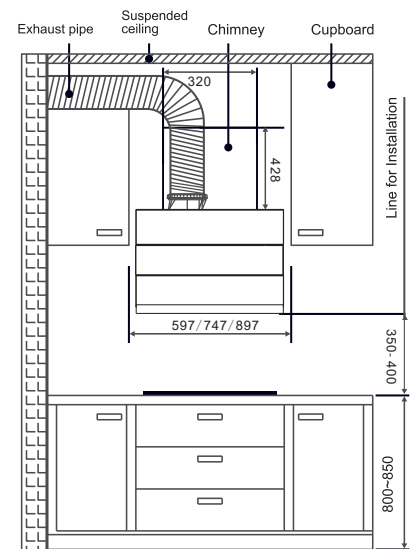
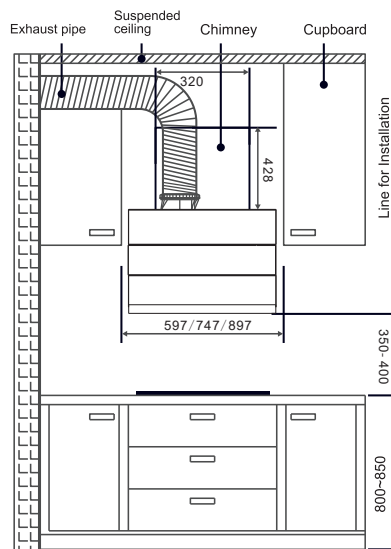
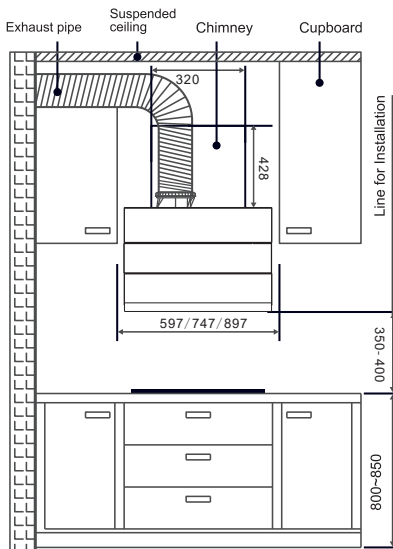

\*Suction is measured at the Inlet side under standard lab conditions with handheld device. The value may vary by +/- 10% depending upon actual usage conditions



RENATA T-90	
90 cm Wall Mounted <b>Filter-Free</b> Hood	
Finish	Black Glass
Motor Power	140W
Speed Level	3 Speed Touch with Gesture Control
Timer Function	Yes
Auto Clean	Heat Autoclean with 30 Hour Timer
Filters	Filter-free
Lighting	LED
Inlet Side Suction*	1300m <sup>3</sup> /h
Product Dimensions (W X H X D) mm	895 X 438 X 456 mm
Warranty	2 years on Hood, 10 years on Motor

**Article No. 534.84.713**

RENATA T-60	
60 cm Wall Mounted <b>Filter-Free</b> Hood	
Finish	Black Glass
Motor Power	140W
Speed Level	3 Speed Touch with Gesture Control
Timer Function	Yes
Auto Clean	Heat Autoclean with 30 Hour Timer
Filters	Filter-free
Lighting	LED
Inlet Side Suction*	1300m <sup>3</sup> /h
Product Dimensions (W X H X D) mm	597 X 438 X 456 mm
Warranty	2 years on Hood, 10 years on Motor

**Article No. 534.84.711**

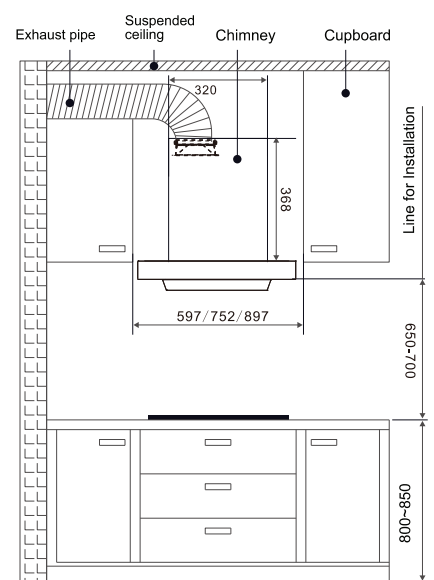
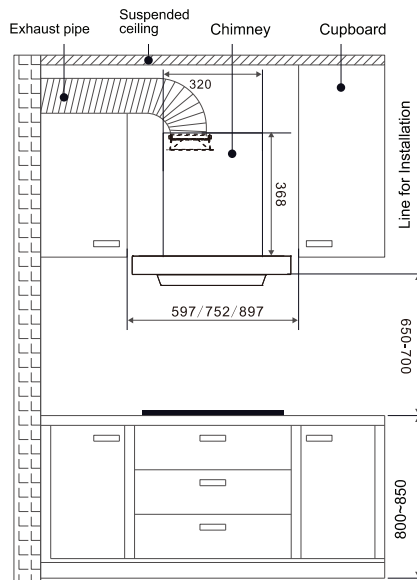

\*Suction is measured at the Inlet side under standard lab conditions with handheld device. The value may vary by +/- 10% depending upon actual usage conditions



### RENATA CURVED 90

90 cm Wall Mounted **Filter-Free** Hood

Finish	Black Curved Glass
Motor Power	180W
Speed Level	3 Speed Touch with Gesture Control
Timer Function	Yes
Auto Clean	Heat Autoclean with 30 Hour Timer
Filters	Filter-free
Lighting	LED
Inlet Side Suction*	1400m <sup>3</sup> /h
Product Dimensions (W X H X D) mm	895 X 550 X 450 mm
Warranty	2 years on Hood, 10 years on Motor

**Article No. 534.84.703**



### RENATA CURVED 60

60 cm Wall Mounted **Filter-Free** Hood

Finish	Black Curved Glass
Motor Power	180W
Speed Level	3 speed touch with gesture control
Timer Function	Yes
Auto Clean	Heat Autoclean with 30 hour timer
Filters	Filter-free
Lighting	LED
Inlet Side Suction*	1400m <sup>3</sup> /h
Product Dimensions (W X H X D) mm	595 X 550 X 450 mm
Warranty	2 year on Hood, 10 years on Motor

**Article No. 534.84.701**

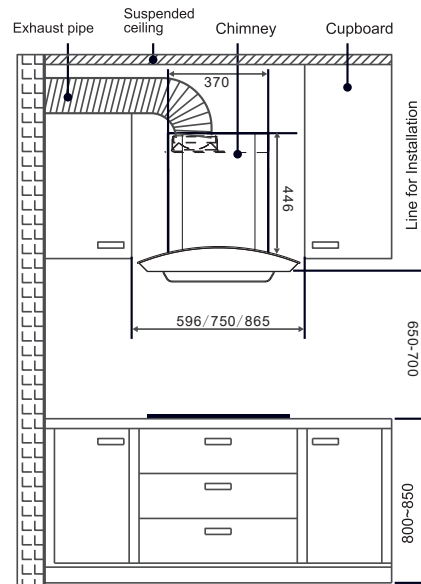
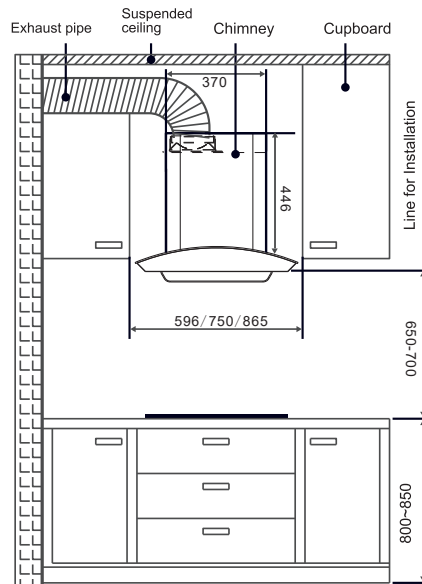

\*Suction is measured at the Inlet side under standard lab conditions with handheld device. The value may vary by +/- 10% depending upon actual usage conditions



# BUILT-IN HOBS

## Where Style Meets Culinary Excellence

Experience the epitome of culinary excellence with the AUGUSTA AND VERENA BUILT-IN HOBS from the ESSENTIA SERIES. The AUGUSTA HOBS feature FULL BRASS BURNERS, ensuring superior heat distribution for precise cooking results. On the other hand, the VERENA HOBS boast of SEMI-BRASS BURNERS, offering a perfect balance of efficiency and elegance. Both hobs are equipped with cast iron pan supports, providing stability even for larger cookware. With the Flame Failure Safety Device (FFSD) and Electric Auto Ignition, cooking becomes not only effortless but also safe, giving you peace of mind while preparing your culinary masterpieces.

Designed to meet the diverse cooking needs of Indian households, the AUGUSTA and VERENA HOBS are available in 3-burner and 4-burner designs, providing flexibility and convenience for any culinary task. Their elegant black tempered glass top adds a touch of sophistication to any kitchen, elevating the aesthetic appeal of your cooking space. Whether you're simmering spices or stir-frying vegetables, these hobs offer the perfect blend of style and functionality, making every cooking experience a delight.

**AUGUSTA**  
FULL BRASS HOBS



**VERENA**  
SEMI-BRASS HOBS



## AUGUSTA and VERENA Hob Burners

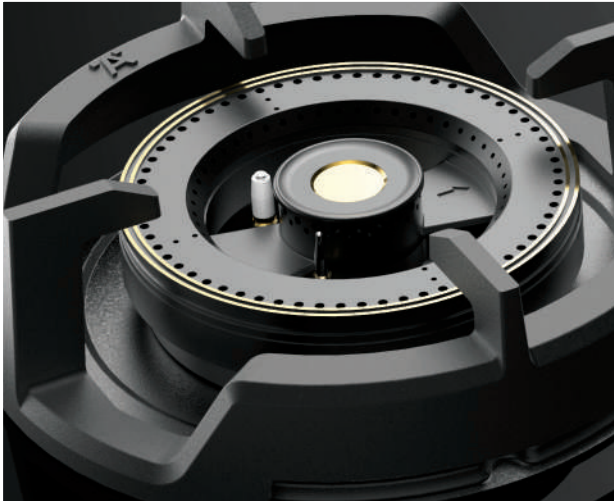

### Triple Ring Burner

The triple ring burner, comes with 3kW power output. Its impressive power and a three ring burner design ensures rapid and uniform heat distribution, essential for tackling the demands of traditional Indian recipes. From searing spices to simmering curries, this burner effortlessly handles diverse cooking techniques with precision and efficiency. Whether preparing elaborate feasts or quick weekday meals, the triple ring burner stands as a testament to reliability, making it the indispensable ally for every culinary enthusiast navigating the rich and flavourful world of Indian cuisine.

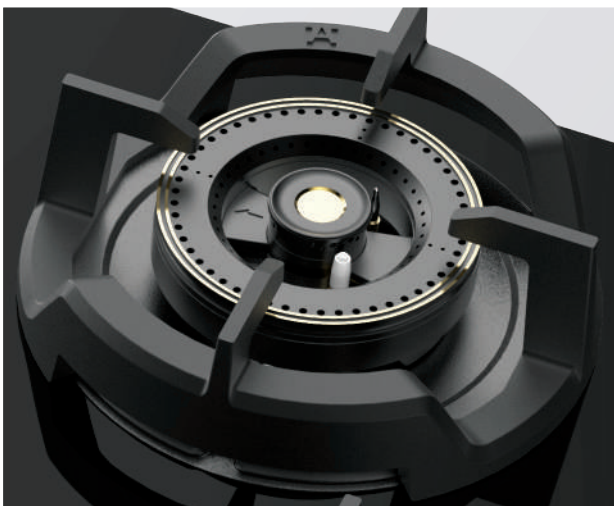

### Mini Triple Ring Burner

The mini triple ring burner, with its efficient 2.5kW power output, emerges as the ideal companion for everyday Indian cooking. Despite its compact size, this burner delivers consistent heat for various cooking tasks encountered in daily cooking endeavours. From sautéing vegetables to boiling rice, the mini triple ring burner excels in versatility and performance, making it a perfect fit for the dynamic and diverse needs of Indian households. Its balanced power output ensures efficient energy utilization without compromising on cooking efficiency, making it an essential addition to any kitchen aiming for convenience and functionality in everyday cooking routines.



### Dual Ring Burner

The dual ring burner, with a power output of 1.7kW, offers a gentle yet efficient solution for mild cooking requirements. Designed to provide precise control over heat levels, this burner is perfect for delicate tasks such as simmering sauces or melting ingredients without the risk of scorching. Its dual-ring design enables an efficient heat distribution without wastage even for smaller vessels, allowing even cooking across various cookware sizes. Whether you're preparing subtle flavours or simply keeping dishes warm, the dual ring burner ensures consistent performance while catering to mild cooking needs with finesse and reliability.

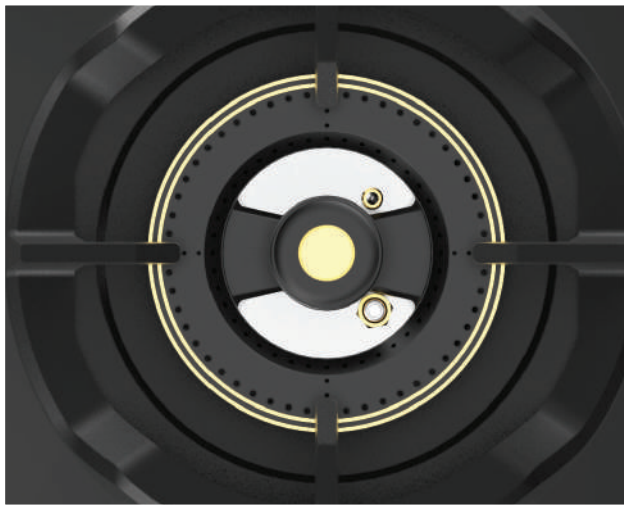

## High Quality Burners

Augusta hobs feature high-quality brass burners, ensuring durable performance and precise heat distribution. Verena hobs offer semi-brass burners, combining efficiency with elegance for a sophisticated cooking experience.



## Spill Proof Design

The spill-proof design of the hob prevents liquids from seeping into the internal components, ensuring easy cleaning and maintenance. This keeps your cooking area tidy and enhances the hob's functional efficiency.

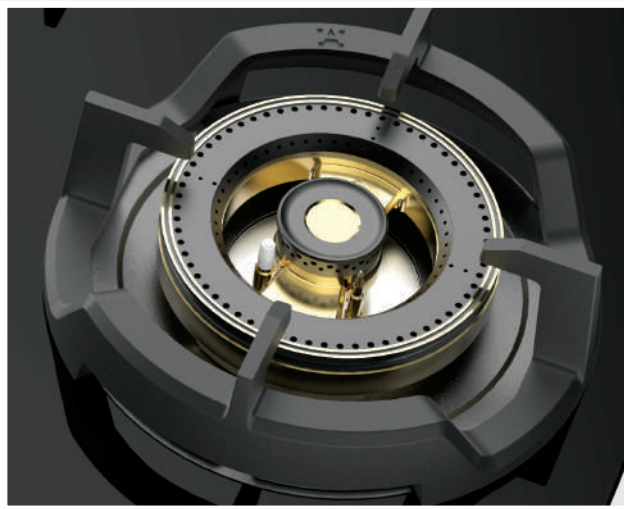

## Cast Iron Pan Support

Cast iron pan supports enhances stability by providing a sturdy base for your cookware, preventing wobbling during cooking. Their robust construction adds durability to your cooking setup, making them an essential feature for a hassle-free cooking.

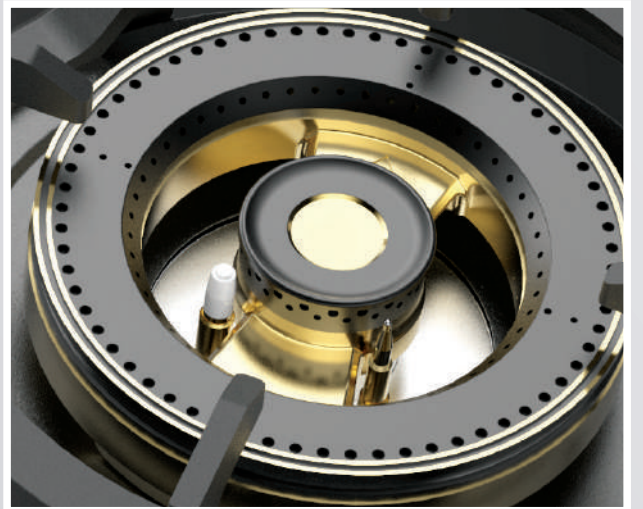

## Flame Failure Safety Device

Each burner of Augusta and Verena hobs come with Flame Failure Safety Device (FFSD), which is a valve that triggers in the event of gas leakage due to accidental extinguishing of the flame. This automatically shuts off gas supply to the burners, mitigating fire hazards caused by gas leaks and ensuring the continual safety of your kitchen and home.



## Heat Resistant Knobs

The heat resistant knobs ensure safe handling by not heating up to extreme levels, remaining cool to the touch, even during heavy duty cooking. This enhances user confidence and comfort while cooking.



## Electric Auto Ignition

Electric Auto Ignition streamlines your cooking experience by effortlessly igniting the burners with just the push of the metal knob, eliminating the need for manual ignition methods. This feature enhances convenience in the kitchen, allowing for swift and hassle-free cooking sessions.



## Elegant Glass Surface

The 8 mm tempered glass surface adds a touch of sophistication and durability to your kitchen, elevating its aesthetic appeal. Its sleek design not only enhances the visual allure but also facilitates easy cleaning, making it a practical and stylish choice for modern households.



AUGUSTA 490	
90 cm, Built-in SPILL PROOF Gas Hob	
Finish	8mm Tempered Glass
Design	4 Burner
Safety	Flame Failure Safety Device
Ignition	Electric Auto
Pan Support	Cast Iron
Knobs	Heat Resistant Knob
Burner Material	4 <sup>th</sup> Generation Brass Burners
Burner Design	Direct Flame
Cooking Zones	
Triple Ring Burner	2 X 3.0kW
Mini Triple Ring Burner	-
Dual Ring Burner	2 X 1.7kW
Product Dimensions: (W X D X H) mm	900 X 525 X 130 mm
Cut-out Dimension: (W X D) mm	828 X 478 mm
Warranty	2 years on Hob, 5 years on Burners & Glass
<b>Article No.</b>	<b>538.61.268</b>

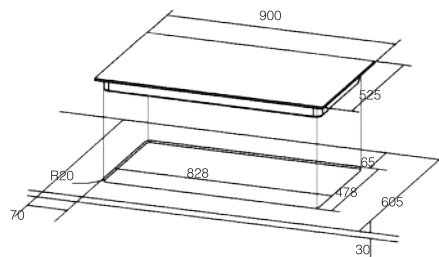

AUGUSTA 480	
80 cm, Built-in SPILL PROOF Gas Hob	
Finish	8mm Tempered Glass
Design	4 Burner
Safety	Flame Failure Safety Device
Ignition	Electric Auto
Pan Support	Cast Iron
Knobs	Heat Resistant Knob
Burner Material	4 <sup>th</sup> Generation Brass Burners
Burner Design	Direct Flame
Cooking Zones	
Triple Ring Burner	1 X 3.0kW
Mini Triple Ring Burner	1 X 2.5kW
Dual Ring Burner	2 X 1.7kW
Product Dimensions: (W X D X H) mm	820 X 525 X 130 mm
Cut-out Dimension: (W X D) mm	685 X 475 mm
Warranty	2 years on Hob, 5 years on Burners & Glass
<b>Article No.</b>	<b>538.61.264</b>

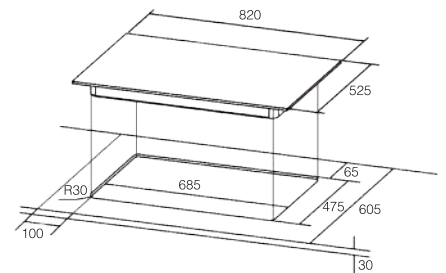



### AUGUSTA 378

78 cm, Built-in SPILL PROOF Gas Hob

Finish	8mm Tempered Glass
Design	3 Burner
Safety	Flame Failure Safety Device
Ignition	Electric Auto
Pan Support	Cast Iron
Knobs	Heat Resistant Knob
Burner Material	4 <sup>th</sup> Generation Brass Burners
Burner Design	Direct Flame

#### Cooking Zones

Triple Ring Burner	2 X 3.0kW
Mini Triple Ring Burner	-
Dual Ring Burner	1 X 1.7kW
Product Dimensions: (W X D X H) mm	780 X 450 X 130 mm
Cut-out Dimension: (W X D ) mm	685 X 405 mm
Warranty	2 years on Hob, 5 years on Burners & Glass

**Article No. 538.61.267**

### AUGUSTA 470

70 cm, Built-in SPILL PROOF Gas Hob

Finish	8mm Tempered Glass
Design	4 Burner
Safety	Flame Failure Safety Device
Ignition	Electric Auto
Pan Support	Cast Iron
Knobs	Heat Resistant Knob
Burner Material	4 <sup>th</sup> Generation Brass Burners
Burner Design	Direct Flame

#### Cooking Zones

Triple Ring Burner	1 X 3.0kW
Mini Triple Ring Burner	1 X 2.5kW
Dual Ring Burner	2 X 1.7kW
Product Dimensions: (W X D X H) mm	700 X 525 X 130 mm
Cut-out Dimension: (W X D ) mm	555 X 475 mm
Warranty	2 years on Hob, 5 years on Burners & Glass

**Article No. 538.61.263**

### AUGUSTA 360

60 cm, Built-in SPILL PROOF Gas Hob

Finish	8mm Tempered Glass
Design	3 Burner
Safety	Flame Failure Safety Device
Ignition	Electric Auto
Pan Support	Cast Iron
Knobs	Heat Resistant Knob
Burner Material	4 <sup>th</sup> Generation Brass Burners
Burner Design	Direct Flame

#### Cooking Zones

Triple Ring Burner	1 X 3.0kW
Mini Triple Ring Burner	1 X 2.5kW
Dual Ring Burner	1 X 1.7kW
Product Dimensions: (W X D X H) mm	600 X 525 X 130 mm
Cut-out Dimension: (W X D ) mm	555 X 475 mm
Warranty	2 years on Hob, 5 years on Burners & Glass

**Article No. 538.61.261**

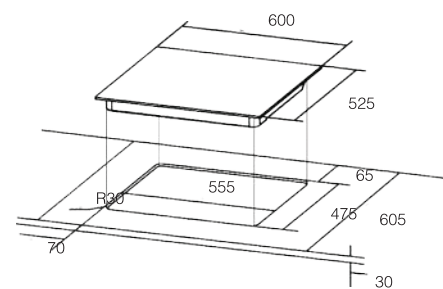
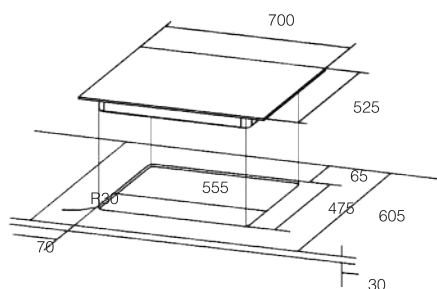
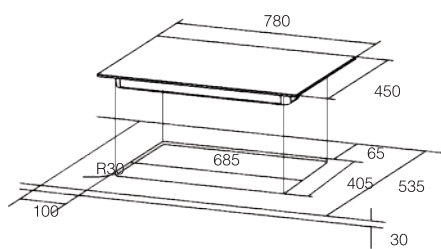



### VERENA 490

90 cm, Built-in SPILL PROOF Gas Hob

Finish	8mm Toughened
Design	4 Burner
Safety	Flame Failure Safety Device
Ignition	Electric Auto
Pan Support	Cast Iron
Knobs	Heat Resistant Knob
Burner Material	4 <sup>th</sup> Generation Brass Burners
Burner Design	Direct Flame

#### Cooking Zones

Triple Ring Burner	2 X 3.0kW
Mini Triple Ring Burner	-
Dual Ring Burner	2 X 1.7kW
Product Dimensions: (W X D X H) mm	900 X 525 X 130 mm
Cut-out Dimension: (W X D) mm	828 X 478 mm
Warranty	2 years on Hob, 5 years on Burners & Glass
<b>Article No.</b>	<b>538.61.278</b>

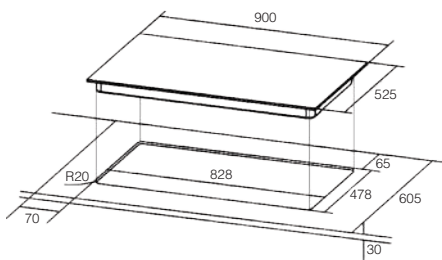

### VERENA 470

70 cm, Built-in SPILL PROOF Gas Hob

Finish	8mm Toughened
Design	4 Burner
Safety	Flame Failure Safety Device
Ignition	Electric Auto
Pan Support	Cast Iron
Knobs	Heat Resistant Knob
Burner Material	4 <sup>th</sup> Generation Brass Burners
Burner Design	Direct Flame

#### Cooking Zones

Triple Ring Burner	1 X 3.0kW
Mini Triple Ring Burner	1 X 2.5kW
Dual Ring Burner	2 X 1.7kW
Product Dimensions: (W X D X H) mm	700 X 525 X 130 mm
Cut-out Dimension: (W X D) mm	555 X 475 mm
Warranty	2 years on Hob, 5 years on Burners & Glass
<b>Article No.</b>	<b>538.61.273</b>

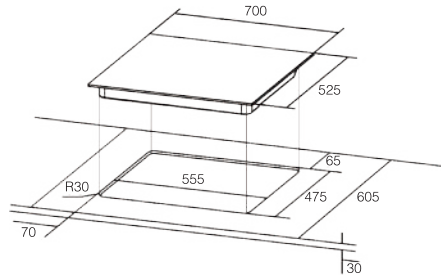

### VERENA 360

60 cm, Built-in SPILL PROOF Gas Hob

Finish	8mm Toughened
Design	3 Burner
Safety	Flame Failure Safety Device
Ignition	Electric Auto
Pan Support	Cast Iron
Knobs	Heat Resistant Knob
Burner Material	4 <sup>th</sup> Generation Brass Burners
Burner Design	Direct Flame

#### Cooking Zones

Triple Ring Burner	1 X 3.0kW
Mini Triple Ring Burner	1 X 2.5kW
Dual Ring Burner	1 X 1.7kW
Product Dimensions: (W X D X H) mm	600 X 525 X 130 mm
Cut-out Dimension: (W X D) mm	555 X 475 mm
Warranty	2 years on Hob, 5 years on Burners & Glass
<b>Article No.</b>	<b>538.61.271</b>

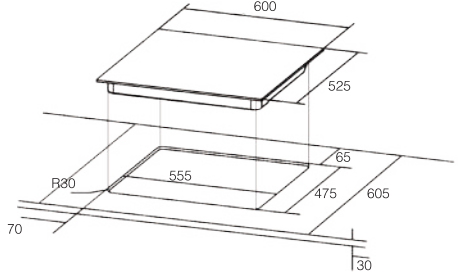





# BUILT-IN OVENS

## New Dimensions to Cooking

Hafele's Essentia Series Built-In Ovens open a new dimension of modern kitchens by offering seamless aesthetics and enhanced functionality. These ovens have been designed to effortlessly integrate into your existing cabinets or walls, delivering a streamlined look to your kitchens.

Discover Hafele's latest innovation in oven technology, the Aurora 80L Built-In Oven, which takes a step further in elevating your kitchen experience. This oven expands the horizon of functionality and aesthetics with features that exude practicality, becoming the perfect choice for the perfect cooking experience. With a large cavity of 80 litres, along with functions for cooking the best roasts, fine bakes, convenient cooking with 8 cooking functions and the ultimate freedom to create your own masterpiece with confidence, this oven is the go-to solution for both amateurs and professionals.

Sporting a convenient control with easy-to-use knobs, an LED display and a full black exterior, the Aurora 80L Built-In Oven offers a modern solution with a sleek and uncluttered design.

# AURORA 80



## Maximising Value of Space

The large 80 liters cavity makes it convenient to cook bigger portions of food at a time. The multiple shelf positions offer enhanced control over the cooking process by enabling you to place the food at optimum position as per the amount of cooking required at the top part or bottom part of the food being cooked.



## Energy Efficient Cooking

The Triple Glazed Glass Door integrated into the Aurora Built-In Oven offers energy efficient cooking even in colder environments by minimising heat loss from the oven cavity.



## Longer Operational Life

The integrated Turbo Cooling System activates once the cooking time has elapsed, contributing to safety of the oven and the user. This unique system rapidly reduces the temperature of the oven using the method of air circulation, expelling the hot air out of the oven and taking in the cold air from the kitchen. This helps reduce the risks of burns on accidentally touching the hot surfaces and minimises the possibility of damage to the sensitive electronics and other components due to exposure to excessive heat. This increases the operational life of the oven and helps maintain a cooler environment in the kitchen.



## Multi-Function Capabilities

Accommodating a wide array of tasks, from baking and broiling to roasting and warming, are the 8 cooking modes that offer precise temperature and time control, giving consistent results every time. Additionally, the cooking timer, which can be set for up to 9 hours, allows you to cook food continuously for an extended period, which is required for slow cooked recipes. This is enabled by the versatile cooking temperature range of 50°C to 250°C. Reducing your number of visits to the oven to start the cooking process is the 24-hour Reservation Function, which is especially useful while cooking kebabs, tikkas or tandoori recipes which require marination for certain hours.



## Even Heat Distribution

The integrated advanced convection technology ensures even distribution of heat throughout the oven cavity, offering even baking and roasting results. Thus, cooking the perfectly roasted chicken, bread loaf or a cake evenly baked from all sides is easy with the Aurora Built-In Oven.



## Rotisserie Mode

Elevate your grilling game with Aurora's Rotisserie function. Watch as your kebabs, tikkas, and tandoori dishes transform into culinary masterpieces crispy on the outside, tender on the inside thanks to continuous, all-around heat exposure. It's like having a professional rotisserie in your own kitchen.



## Versatility in Cooking

Aurora Built-In Oven sports a built-in digital timer which enables precise setting of the cooking time and stops the cooking process once the set time has elapsed. This flexibility in setting the time to a resolution of seconds gives you a refined control over the cooking process. This is especially useful in, for example, grilling at high temperature for getting the required browning on your kebabs or tikkas. Also, the Reminder Function reminds you to start the cooking process once the set time, which can be up to 10 hours, has elapsed.



## Child Lock

Ensuring peace of mind is the child lock feature which, when activated, disables the controls, avoiding any accidental changes in settings or switching on of the oven.



## Convenient Control

The knob control with LED display offers a convenient and easy way of controlling the oven and managing the cooking settings.

## Premium Aesthetics

Delivering premium aesthetics to your kitchen is the complete black exterior with the easy-to-use knobs and LED display, which presents the oven as a modern solution with a sleek, uncluttered design.



## AURORA 80

60 cm Built-In Oven

Capacity	80 L
Energy Efficiency Class 2024 (EU)	A (EU)
Ultra Cool Door	Triple Glass Insulation
Features	LED Display, Easy-tronic Controller, 3 Layer Full Black Glass Exterior
Cooking Modes	8 Cooking Functions. Bottom Heat, Defrosting, Conventional, Conventional with Fan, Radiant Grilling, Double Grilling, Double Grilling with Fan, Convection
Cooking Assistance	Defrost, Convection along with Fan, Radiant Grill, Double Grill
Accessories	Rotisserie Skewer Set - 1, Wire Shelf - 1, Universal Pan - 1
Product Dimensions: (W X H X D) mm	595 X 595 X 575 mm
Warranty*	2 Years on Product
<b>Article No.</b>	<b>538.61.621</b>

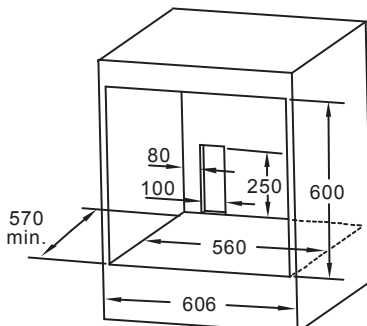
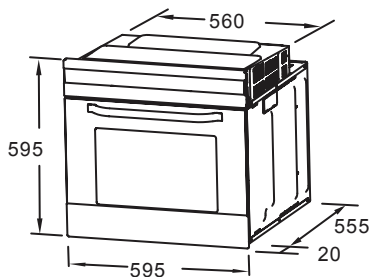

\*Warranty terms and conditions apply



# MICROWAVE with Grill

## Convenience in Cooking, Redefined

Microwaves have revolutionised cooking by drastically reducing the re-heating and preparation times, offering unparalleled convenience. Fast and efficient, these appliances enable you to cook a variety of recipes easily even with minimal cooking experience.

Hafele's latest introduction to Essentia Series, the Aurora 25L Built-in Microwave with Grill redefines convenience in the realm of modern cooking appliances. A blend of innovation, style and practicality, this microwave offers enhanced convenience with the 8 preset autocook programs that make cooking food a breeze and the Multi-Stage cooking function which automates the cooking process.

Designed to seamlessly fit into the existing cabinets, this microwave offers seamless integration into your kitchen space. With a matt black finish with full glass exterior, along with an uncluttered control panel with LED display, the Aurora 25L Built-In Microwave with Grill complements your premium interiors.

# AURORA 25



## Advanced Cooking Capabilities

Laden with advanced cooking functions like defrost, combination cooking and grilling, Aurora microwave offers a versatile cooking solution with precise and consistent results.



## Autocook Menu

The Aurora microwave simplifies meal preparation with 8 expertly designed pre-set cooking programmes. Whether you're a seasoned chef or a beginner, achieving perfect results is just a button away. Each programme is finely tuned for precise time and temperature control, ensuring consistently delicious outcomes every time.



## Tailored Culinary Creations

Experience unparalleled cooking flexibility with the Multi-Stage Cooking mode. This feature allows you to seamlessly combine two cooking modes, such as microwave and grill, to automatically transition from one to the next. Customise cooking time, and mode to create your own auto cook programme, delivering restaurant-quality dishes with minimal effort.



## Powerful Performance

The 900W power output of the microwave cooks and re-heats food quickly while the 1000W grill gives perfect browning. The grill element helps to evenly brown the surface of food, making it crispy and enhancing the texture. When operated in combi mode (microwave + grill), this microwave gives you food that is crispy on the outside and perfectly cooked from the inside. With 5 microwave power levels to choose from, cooking in the microwave is more flexible than ever before.



## User Friendly Solution

This microwave comes with functions that make it the perfect solution for a convenient microwave experience. The defrost function can bring the frozen food to normal temperature, either according to the weight, or by setting a timer. The uncluttered design of the control panel with minimum number of buttons, along with the user-friendly display offers an easy to use and convenient cooking solution. The display allows you to easily navigate through various settings and monitor the cooking progress effortlessly.



## Crystal-Clear Digital Display

The user-friendly display is designed for straightforward operation, allowing you to navigate settings and monitor progress effortlessly.



## Customizable Power Settings

With 5 available power levels, this microwave offers a tailored cooking experience, suitable for your specific cooking needs. Thus, cooking tikkas or kebabs which are tender on the inside and crisp on the outside is now more convenient than ever before. Depending upon the dish being cooked, the power levels can be adjusted for thorough cooking as well achieving perfect browning on the outside.



## Child Lock

Guaranteeing peace of mind is the child lock function that, once activated, disables the controls, avoiding accidental change of settings.



## AURORA 25

39 cm Built-In Microwave with Grill

Capacity	25 L
Rated Power (Microwave)	1450W (Input)/ 900W (Output)
Rated Input Power (Grill)	1000W
Features	LED Display, LED White Interior Light, 3 Layer Full Black Glass Exterior, Black Knob and Handle, Mechanical Control
Cooking Modes	8 Auto Cook Menus, Defrost (by time/ by weight), Quick Start, Overheat Protection,
Cooking Assistance	Defrost, Convection along with Fan, Radiant Grill, Double Grill
Accessories	Glass Tray - 1 Turntable Ring Assembly - 1 Grill Rack - 1
Product Dimensions: (W X H X D) mm	595 X 388 X 400 mm
Warranty*	2 Years on Product
<b>Article No.</b>	<b>538.31.580</b>

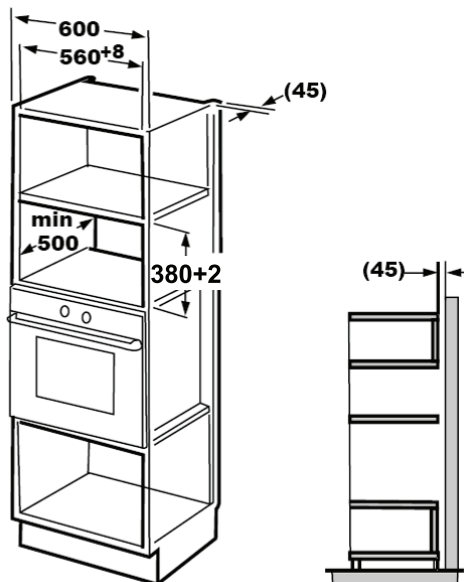

\*Warranty terms and conditions apply

**Mumbai Design Centre:**

Haji Moosa Patrawala Ind.(SOBO)  
Estate, Near Famous Studio,  
Mahalaxmi (West), Mumbai - 400 011  
Tel.: 022 6264 7100

**Mumbai Design Centre:**

#2 Filix Building, Opp. Asian Paints,  
L.B.S. Marg, Bhandup (West),  
Mumbai - 400 078  
Tel.: 022 2596 9660 / 2596 9787 /  
2594 7305

**Pune Design Centre:**

Showroom No. 2, Ground Floor,  
F P No. 403, A/2, ICC Trade Tower,  
Senapati Bapat Marg,  
Shivaji Nagar, Pune - 411 016  
Tel.: 020 2563 3301  
Fax: 020 2563 3302

**Pune Office:**

Office No. 12, Vastushree Complex,  
Survey No.587,  
Near Hyde Park, Gultekdi,  
Market Yard, Pune - 411 037  
Tel.: 020 2426 6264  
Fax: 020 2426 6274

**Ahmedabad Office:**

Hafele India Pvt. Ltd., Office No. 302,  
3<sup>rd</sup> Floor, Shangrila Arcade, Near  
Shyamal Cross Road, Satellite,  
Ahmedabad - 380 015  
Tel.: +91 79695 55505 / 88662 20505

**New Delhi Office & Design Centre:**

D-89 , 1<sup>st</sup> Floor, Okhla Phase-I,  
New Delhi - 110 020  
Tel.: 011 6657 4999  
Fax: 011 4160 5482

**Chandigarh Office:**

Godrej Eternia, Wing A, 2<sup>nd</sup> Floor,  
WL2, Plot No.70, Industrial Area  
Phase I, Chandigarh - 160 002  
Mob.: +91 85588 44448

**Jaipur Office:**

Airport Plaza, Plot No.15, 1<sup>st</sup> & 2<sup>nd</sup>  
Floor, Tonk Road, Next to Cocoon  
Hospital, Jaipur, Rajasthan - 302 016  
Mob.: +91 98887 77796

**Kolkata Design Centre:**

PS PACE, Premises No. 1/1A,  
Mahendra Roy Lane, Topsia,  
Kolkata - 700 046  
Tel.: 033 4008 6814 / 4008 9268  
Fax: 033 2498 8020

**Kolkata Office:**

Office No. 1001, PS Continental,  
10<sup>th</sup> Floor, 83/2/1 Topsia Road,  
Near Vishwakarma Building.  
South Kolkata - 700 046  
Tel: 033 2285 0104 / 5 / 6

**Bangalore Office & Design Centre:**

Incubex Nestavera Spaces Pvt Ltd,  
No:13, Langford Place, Langford  
Road, Shanti Nagar,  
Bangalore - 560 025  
Tel.: 080 4132 6116  
Fax: 080 4132 6226

**Bangalore****Hafele Appliances Gallery:**

No. 2/1, Shiv Manor, Langford Road,  
Shantinagar, Bangalore - 560 027  
Tel.: 080 4142 6336

**Hyderabad Office & Design Centre:**

SJR Building - # 1-57/89/1 & 1-57/89/2  
Opp Allahabad Bank, Gachibowli,  
Hyderabad - 500 032  
Tel.: 040 2955 7578 / 88

**Chennai Office & Design Centre:**

1<sup>st</sup> Floor No.24, College Road,  
Nungambakkam, Chennai - 600 006  
Tel.: 044 4215 1542  
Fax: 044 2446 0922

**Cochin Office:**

Jomer Symphony, 5<sup>th</sup> Floor, 48/1744  
C 34, Chalikkavattom, North  
Ponnuranni, Vyttila, Cochin - 682010

**Sri Lanka:****Hafele Office and Design Centre:**

52, Nandana Gardens  
(On Duplication Road), Colombo 04.  
Tel: +94 112 500 501  
Fax: +94 112 500 553

**Hafele Design Centre:**

752, Peradeniya Rd,  
Kandy, Sri Lanka.  
Tel.: +94 812 223 338

**Bangladesh Corporate Office:**

House 21, 9<sup>th</sup> Floor, A9 Bashati  
Horizon, Road 17, Block B, Banani  
C/A, Dhaka 1213, Bangladesh  
Tel.: +88-01844018432 / 33

**Bangladesh Design Center:**

House - 106, Road - 12,  
Block - E, Banani, Dhaka - 1213  
Tel.: +880 2 - 4881 0380 / 81

**Nepal:**

UHS Holdings Pvt. Ltd.  
Kathmandu-2, Gairidhara Chowk,  
Nepal.  
Mob.: +977 98023 38800

**Bhutan:**

SMART HOMES  
Gr. Floor, Druk Building (Opp Helipad)  
Babesa -Thimpu Expressway, Thimpu  
Tel.: +975 - 2 - 333 419  
Mob.: +975 - 7727 7615 / 1783 9717 /  
7711 4228 / 1760 0663 / 1766 9840



# HÄFELE

Maximising  
the value of space.  
Together.

**Mumbai Corporate Office:**

Office No. 3, Building "A", BETA,  
I Think Techno Campus, Off J.V.L.R.,  
Opp. Kanjurmarg East, Mumbai – 400 042.  
Tel.: 022 6142 6100 | Fax: 022 6702 0531.

Toll Free Customer Care: 1800 266 6667  
Customer Care WhatsApp: +91 97691 11122  
customer care@hafeleindia.com  
info@hafeleindia.com

Follow us on

